

# Goat

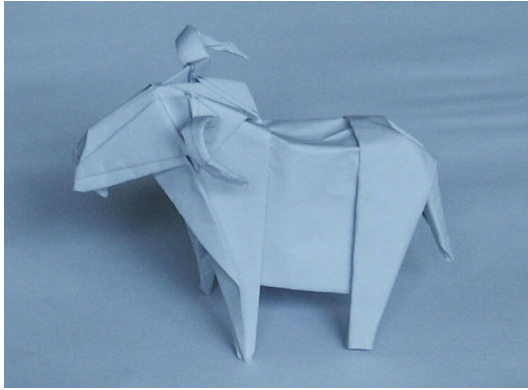

Developed in Jan '04 by Ching-Yu Hung

Start with a 2:1 rectangular piece of paper. This model needs paper with the same color on both sides.

**1**  
Make a waterbomb base out of half of the paper.

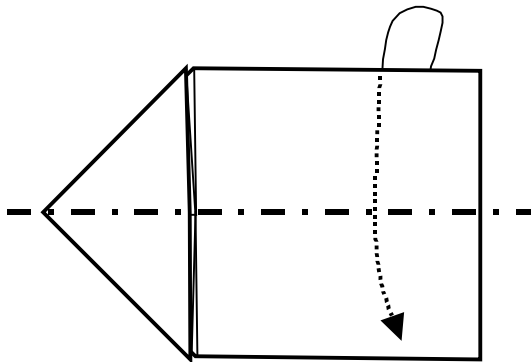
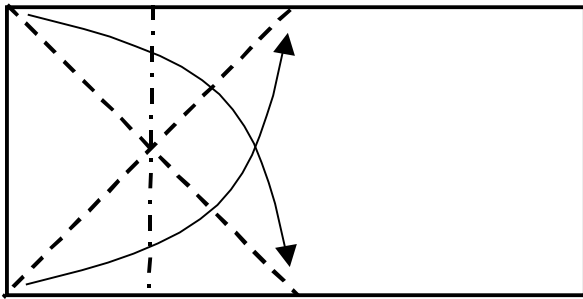

**2**  
Fold along the symmetrical line.

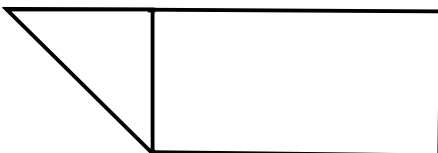

**3**  
Do a rabbit-ear fold on **both** outside flaps. Note that the fold line from the front tip of the design does not start from the exact tip, but somewhat lower. This makes the goat's mustache easier to fold later.

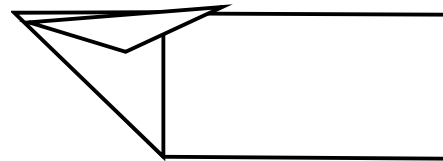
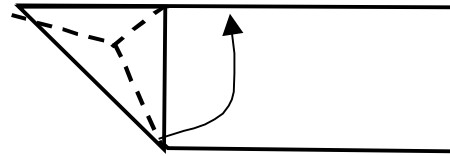

**4**  
Fold the mountain and valley folds symmetrically on both sides of the design. This forms the rough shape of front legs and head.

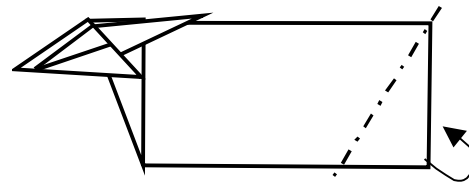
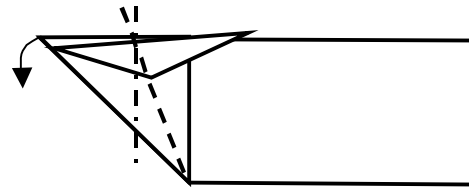

**5**  
Tuck in the rear-down corners to prepare for the tail. Note we fold in less than 45-degree, otherwise the body will become too short.

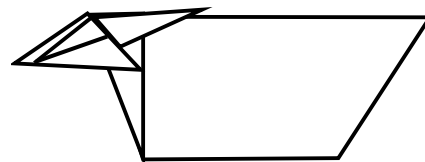

6

Fold the mountain and valley folds symmetrically on both sides of paper as shown, to form the middle section of the body and to provide room to form the belly and legs.

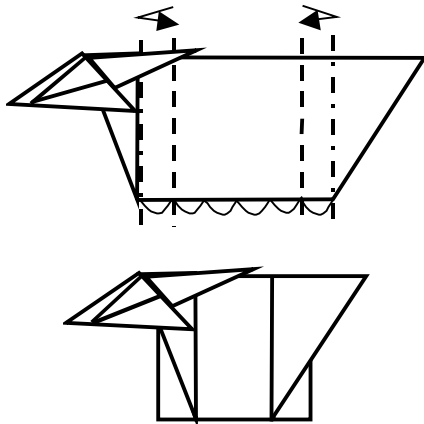

7

Open up the design from the middle, and work from the inside, one side at a time. We need to raise the belly line and define the inside edges of legs. For the upper side, fold down the middle flap as shown.

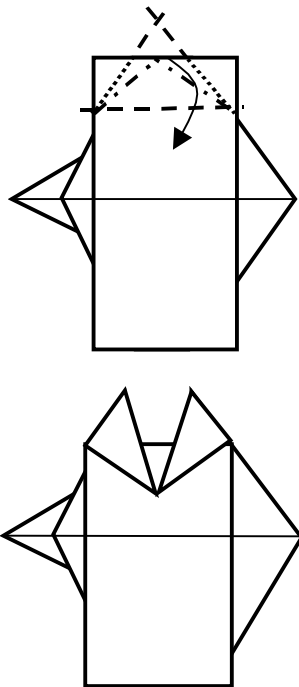

8

(Optional) fold the middle flap up again, about mid-way, to sharpen the angle for the legs

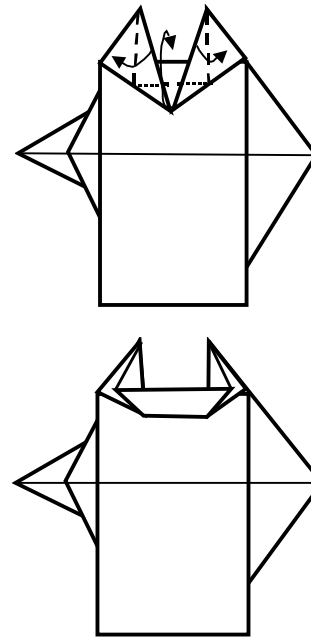

9

Repeat steps 7 and 8 for the lower side, then close the design. You should see this.

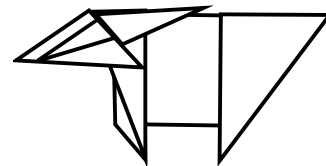

10

Now we work on the head details. Pinch sharp the horns. Fold down the nose-tip. Tuck in the chins. Also tuck in the front part of the legs so they are flush.

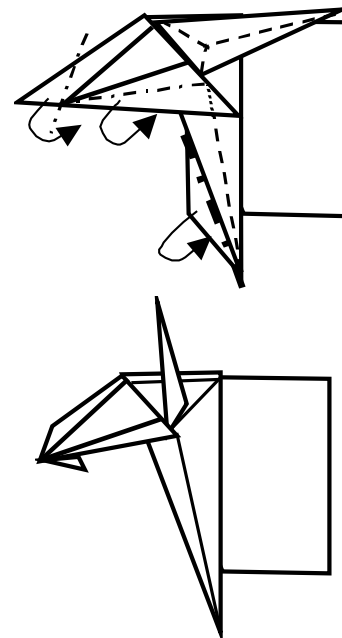

**11**

Now we work on the rear. Squash-fold the rear end.

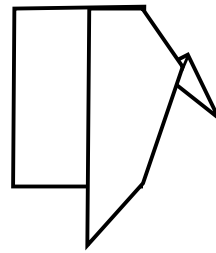
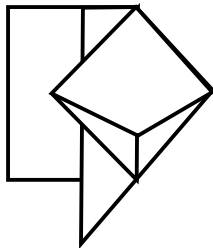
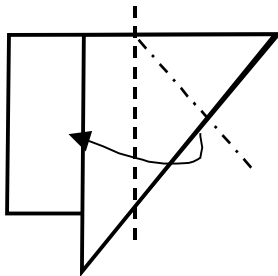

**14**

Use a pencil to curl down the horns. Pinch the mustache so that it's flat looking from the front of the goat, and thin from the side. Shape the body to 3-D like, and you're done.

**12**

Petal-fold the rear flap to form the tail.

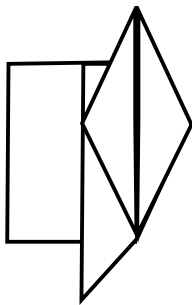
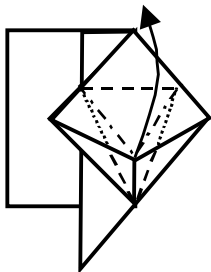

**13**

Close the rear end and reverse-inside-fold the tail down.